

Hex Code Table		
✓ FMXXXX	Length (L)	
FM0650	1	
FM0651	2	
FM0652	3	
FM0653	4	
FM0654	5	
FM0655	6	
FM0656	7	
FM0657	8	
FM0658	9	
FM0659	10	
FM0660	11	
FM0661	12	
FM0662	13	
FM0663	14	
FM0664	15	
FM0665	16	
FM0666	17	
FM0667	18	
FM0668	19	
FM0669	20	
FM0670	21	
FM0671	22	
FM0672	23	
FM0673	24	
FM0674	25	
FM0675	26	
FM0676	27	
FM0677	28	
FM0678	29	
FM0679	30	
FM0680	31	
FM0681	32	
FM0682	33	
FM0683	34	
FM0684	35	
FM0685	36	
FM0686	37	
FM0687	38	
FM0688	39	
FM0689	40	
FM0690	41	
FM0691	42	
FM0692	43	
FM0693	44	
FM0694	45	
FM0695	46	
FM0696	47	
FM0697	48	
FM0698	49	
FM0699	50	
FM0700	51	

## Metric Spacers 10 mm

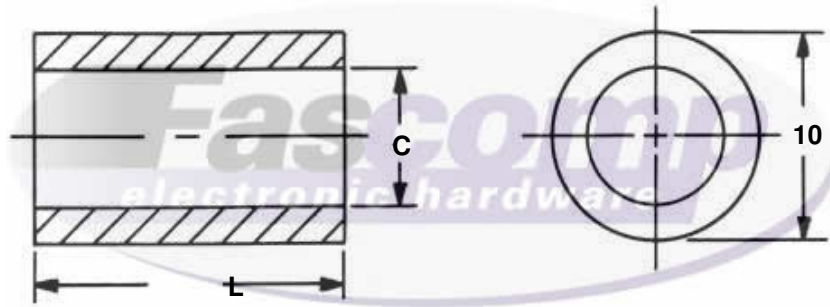

Create a part number:

Length	Clearance	Material	Finish
FMXXXX	XX	XX	XX
_____ . _____ . _____ . _____			

Hole Clearance Code (XX)			
✓	Code (XX)	Thread	C +0.3 -0.0
	35	M3.5	3.7
	4	M4	4.3
	5	M5	5.3

Material		
✓	Material Code (XX)	
	A	Aluminum
	B	Brass
	S	Steel
	SS	Stainless Steel
	N	Nylon

**Tolerances  
Unless otherwise Specified**  
 .xxx +/- .13mm  
 .xx +/- .26mm  
 Angular +/- 1 Degree  
 Linear +/- .13mm  
**Break all sharp edges**

✓ Compatible Finish		
A, B, S, SS	0	Plain
B, S	5	Nickel Plate (QQ-N-290)
A	6	Iridite #14 Gold (MIL-C-5541E)
A	7	Iridite Clear (MIL-C-5541E)
A	9	Alodine 1200
B, S	12	Zinc Clear (ASTM-B-633)
B, S	16	Electro Tin (MIL-T-10727 TYPE 1)
SS	20	Passivation (MIL-F-14072D)
A	22	Clear Anodize (MIL-A-8625-TYPE2) (Sulphuric) Hot Water Seal (Clear)
A	24	Black Anodize (MIL-A-8625)
B, S, SS	26	Black Oxide
B, S	28	Zinc Yellow (ASTM-B-633)



Source Control Drawing:  
To be produced by  
Fascomp Electronic Hardware

This document is the property of Fascomp Inc. and shall not be reproduced, distributed, or used as a basis for manufacturing without written permission from Fascomp Inc.